

June 8, 1937.

V. A. BOKER

2,083,490

LAYING-OUT DEVICE

Filed July 31, 1935

2 Sheets-Sheet 1

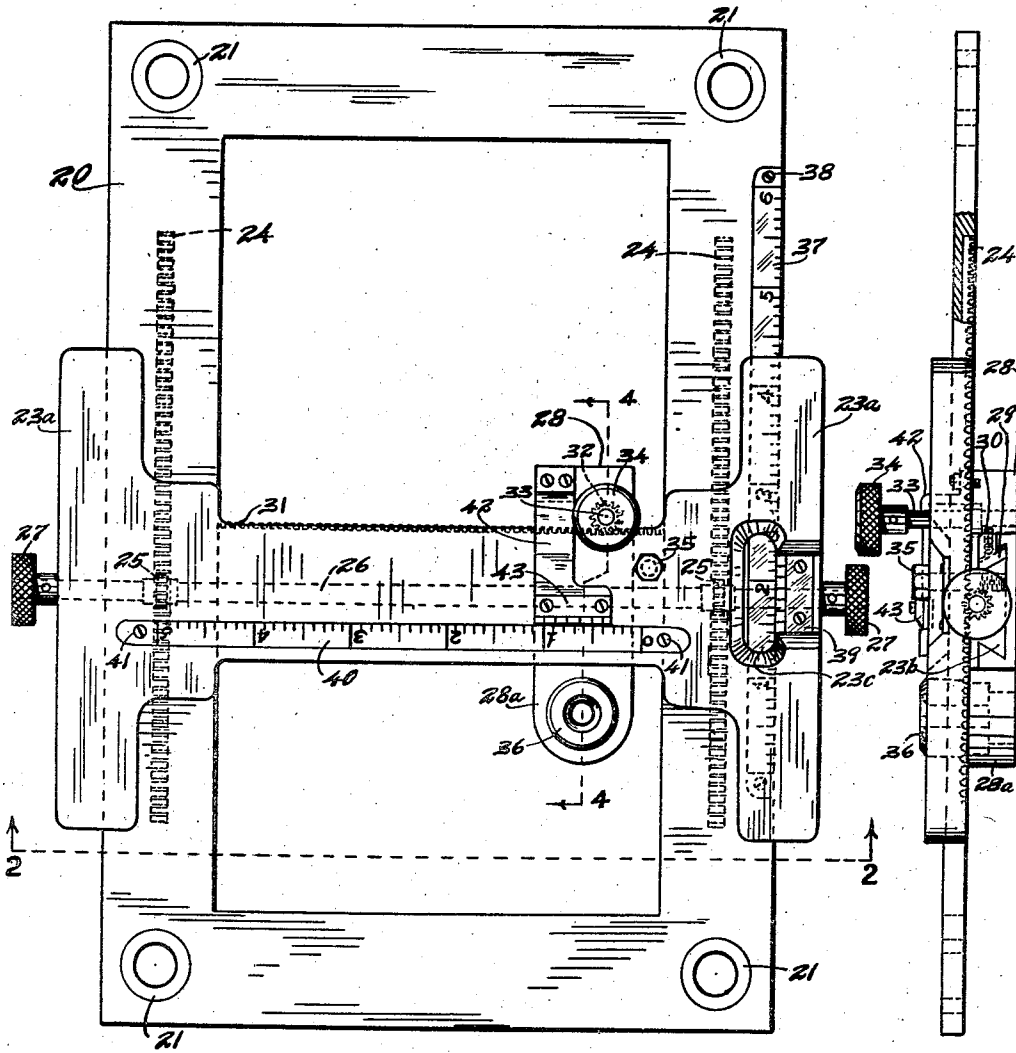

Fig. 1.

Fig. 3.

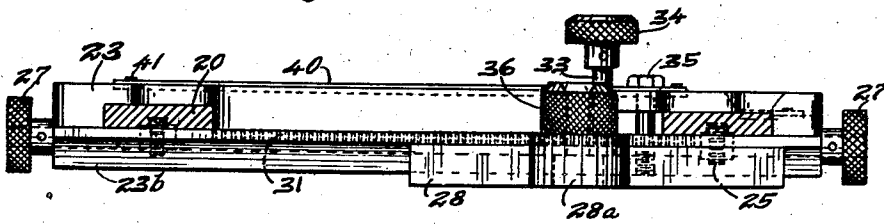

Fig. 2.

Inventor
VITUS A. BOKER
BY *Chas. C. Reif*
Attorney

June 8, 1937.

V. A. BOKER

2,083,490

LAYING-OUT DEVICE

Filed July 31, 1935

2 Sheets-Sheet 2

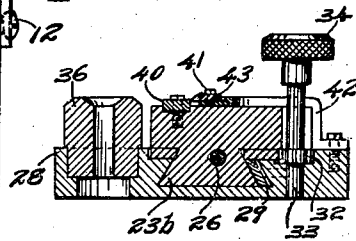
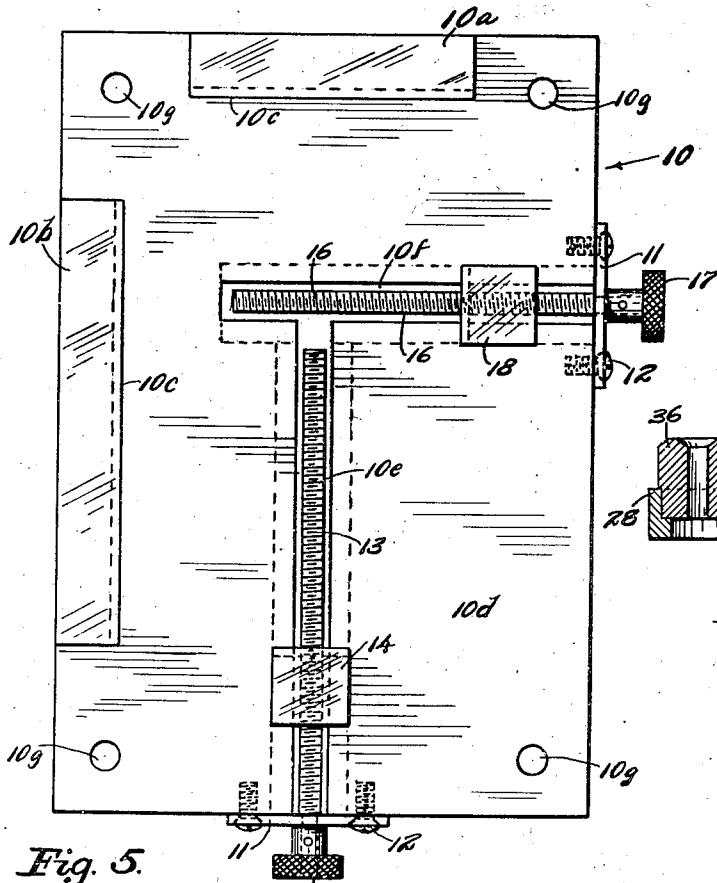
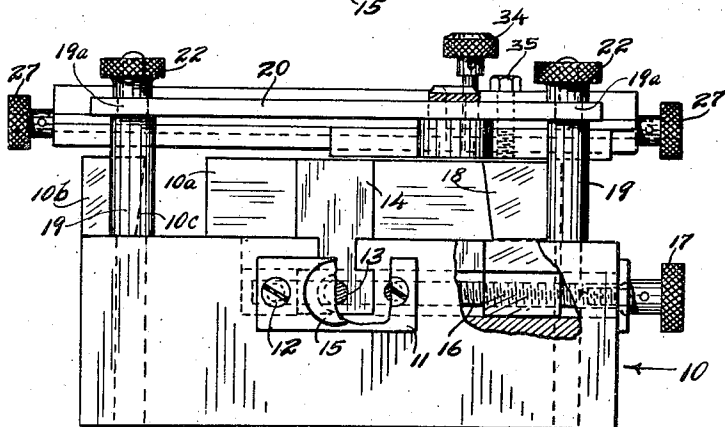

Fig. 4.



Inventor
VITUS A. BOKER
By *Chas. C. Reef*
Attorney

UNITED STATES PATENT OFFICE

2,083,490

LAYING-OUT DEVICE

Vitus A. Boker, Minneapolis, Minn.

Application July 31, 1935, Serial No. 33,989

5 Claims. (Cl. 77-62)

This invention relates to a device or instrument for locating points on a die plate for drilling or other operations.

In making dies in a die plate, particularly female dies, the initial operations often and usually do include drilling holes which determine the limits and outline of the desired opening. It is necessary to locate the centers of these holes with great accuracy. It is customary to lay out a diagram of the centers, the distance between said centers being determined by trigonometrical or other mathematical calculations. After the distances are determined it has been the common practice to stand the die plate on a carefully finished surface and to mark lines thereon by means of a height gauge which is also placed on said surface. After the lines in one direction have been marked the die plate is turned at right angles on said surface and marks in a direction at right angles to said direction are made, the marks thus crossing to determine the point of said centers. The point is then marked with a center punch and the hole drilled. This is a rather slow and tedious operation.

It is an object of this invention to provide a device by means of which the center points on a die plate can be quickly located after the distances between them are calculated.

It is a further object of the invention to provide such a device comprising means for positioning the die plate and clamping it into position together with means movable over said die plate and carrying a guide such as a drill or punch guide for determining the desired center points.

It is another object of the invention to provide a device comprising a member for supporting a die plate having means thereon for positioning and holding said plate, a frame carried by and above said member in fixed relation thereto having movable means thereon carrying a guide member with means for moving said movable means and guide member over said die plate, scales being provided to determine the position of said guide member together with means for holding said guide member firmly in position.

These and other objects and advantages of the invention will be fully set forth in the following description made in connection with the accompanying drawings, in which like reference characters refer to similar parts throughout the several views and in which:—

Fig. 1 is a plan view of the frame member carrying the guide means;

Fig. 2 is a vertical section taken on line 2-2 of Fig. 1 as indicated by the arrows;

Fig. 3 is a view in side elevation of Fig. 1, a portion being broken away and another portion shown in vertical section;

Fig. 4 is a vertical section taken on line 4-4 of Fig. 1 as indicated by the arrows;

Fig. 5 is a plan view of the base or supporting member used; and

Fig. 6 is a view in end elevation of the assembled device, certain portions being broken away and others shown in vertical section.

Referring to the drawings, a device is shown comprising a base member 10. While this member might take various forms, in the embodiment of the invention illustrated it is shown as a block rectangular in plan and rectangular in horizontal and vertical cross section. Said block as shown thus has plain surfaces on two sides thereof at right angles to each other. Member 10 has portions 10a and 10b upstanding therefrom at two of its sides forming abutments. These portions are at right angles to each other and each has an inner surface 10c which slopes outwardly from its top downwardly to the flat finished supporting surface 10d at the top of block 10. Block 10 has formed in its upper portion a T-slot 10e extending longitudinally thereof parallel to the sides thereof and said block also has another similar T-slot 10f extending thereinto from one side parallel to its ends and communicating with the end of slot 10e. The narrow portions of said T-slots extend to the surface 10d. Plates 11 are secured to member 10 at the outer ends of T-slots 10e and 10f, said plates being secured by screws 12. A screw member 13 has a reduced portion journaled in one of the plates 11 and extends longitudinally in slot 10e centrally thereof, the same being threaded in the lower portion of a clamping member 14 which fits in and is slidable in the slot 10e. Screw 13 has a knurled handle or knob 15 secured to its outer end. It will be seen that by turning handle 15 screw 13 will be rotated and member 14 moved relatively to member 10. Another screw member 16 has a reduced portion threaded in the other plate 11 and extends longitudinally of and centrally of slot 10f. Screw member 16 has a knurled handle or knob 17 secured to its outer end and said screw extends through the lower portion of a clamping member 18 slidable in slot 10f. It will be seen that by turning handle 17 screw 16 will be rotated and member 18 will be moved relatively to member 10. It will also be obvious that members 14 and 18 are movable toward and from abutment members 10a and 10b respectively. Member 10 has vertical holes 10g therein adjacent the corners thereof which receive the reduced

portions of pins 19 which extend vertically from block 10.

A frame designated 20 is provided comprising a plate of rectangular form with a rectangular opening therein, the same thus having parallel sides and ends. Said frame has bushings 21 therein accurately bored to fit over upper reduced portions 19a of pins 19. Said reduced portions 19a are threaded at their upper ends to receive knurled clamping nuts 22. The side portions of frame 20 form guides for a slide 23 having end portions 23a of considerable length fitting on the top and the outer sides of said sides of said frame. Said sides of frame 20 have rack members 24 inserted therein on their under sides with which mesh pinions 25 carried on a shaft 26 journaled in member 23. Shaft 26 has secured to its ends the knurled knobs or handles 27. It will be seen that by turning handles 27 shaft 26 will be rotated and slide 23 will be traversed lengthwise of frame 20. The intermediate portion of slide 23 has its lower side formed as a dove-tailed guide 23b and a slide 28 has a dove-tailed slot fitting guide 23b and movable lengthwise thereon. A gib 29 is disposed between one side of guide 23b and slide 28. One or more screws 30 are threaded into the side of slide 28 engaging gib 29 so that it can be tightened when necessary. One side of the intermediate portion of slide 23 is formed as a rack 31 with which meshes a pinion 32. Pinion 32 is secured to a shaft 33 journaled in one side of slide 28, said shaft having a knurled handle or knob 34 secured to its upper end. It will be seen that by turning handle 34 shaft 33 will be rotated and slide 28 will be traversed lengthwise of slide 23. A headed screw 35 extends through the top of slide 23 and is threaded into the spaced lower portion of said slide, said screw having its head at the top of said slide where it is accessible for a wrench. Slide 28 has a portion 28a projecting at one side which is bored to receive a bushing 36 having a knurled upper enlarged portion resting on said portion 28a. Bushing 36 is bored to form a guide for a drill or other tool.

One side of frame 20 has a scale 37 set therein held by the screws 38 so that it is flush with the top of said side. One portion 23a is formed with an opening or slot 23c through which scale 37 is visible and said portion 23a has secured therein a vernier scale 39 cooperating with scale 37. A scale 40 is secured to the top of slide 23, being held by the screws 41. Slide 28 has a small bracket 42 extending over the top of slide 23 and having secured thereto a vernier scale 43 cooperating with scale 40.

In operation, a die plate in which an opening is to be formed will be supported on surface 10d or on parallels or small accurately machined blocks placed on surface 10d. Two sides of the die plate will be positioned against the surfaces 10c of the abutments 10a and 10b. Clamping members 14 and 18 will then be moved in against the die plate by rotating handles 15 and 17 respectively. The die plate will be firmly clamped in position due to the inclination of the surfaces 10c. In practice this inclination is approximately 5 degrees. When the die plate is thus positioned and clamped the frame 20 which has been removed will be placed in position on the pins 19 and clamped by the nuts 22. Slide 23 can now be moved by the wheels 27 and guide 36 may be brought over the desired point on the plate for one of the centers. From this point member 36 can be moved by moving slides 23

and 28 to locate the other centers. The scales 37 and 39 are graduated so that with the vernier scale slide 23 can be moved accurately to thousandths of one inch. By means of scales 40 and 43 slide 28 can be accurately positioned to thousandths of an inch. When member 36 is positioned over the various centers the slides are clamped in position by turning screws 30 and 35. The holes in the die plate can then be drilled at once, using member 36 as the guide for the drill. The device then serves as a template. Different bushings 36 can be placed in portion 28a to suit various sizes of drills. The various centers to be located on the die plate can thus be quickly located and the holes drilled at once. A great deal of time is thus saved in locating the centers of the holes and drilling them. The die is thus accurately and quickly made, frame 20 can be removed and base plate 10 placed on a flat surface or table on one or both of the flat sides and the location of the holes made in the die plate checked or other measurements made by means of a height gauge.

From the above description it is seen that applicant has constructed a comparatively simple and very efficient device for locating various points on a die plate or other member to be drilled or worked upon. The device is easily operated and is very accurate and rugged in construction. The same has been amply demonstrated in actual practice and found to be very successful and efficient.

It will, of course, be understood that various changes may be made in the form, details, arrangement and proportions of the parts, without departing from the scope of applicant's invention, which generally stated, consists in a device capable of carrying out the objects above set forth in the parts and combinations of parts disclosed and defined in the appended claims.

What is claimed is:—

1. A device of the class described having in combination, a base with flat sides at right angles to each other and having a top supporting flat surface for receiving a die plate, means on said member for positioning said die plate and clamping the same in position, a plurality of frame-receiving and holding means rigid with said base member, a removable rigid integral openwork frame mountable on said means and above said member in accurate fixed relation thereto, a drill guide carried on said frame, means at each side of said frame operated by a common means for moving said drill guide on said frame and over said die plate in one direction, means for moving said drill guide in another direction at right angles thereto so that said guide is movable over substantially the whole area of said surface within said frame, scales on said frame for determining the position of said guide and means for clamping said guide in fixed position relative to said frame whereby holes to be drilled can be quickly and accurately located and drilled at once in said die plate and said frame subsequently removed so that said base member can be placed on a flat surface on one or both of said flat sides and said holes checked.

2. A device of the class described having in combination, a base member rectangular in plan having flat sides at right angles to each other and having a top supporting flat surface adapted to receive a die plate, means on said member against which said plate may be placed to position it, movable clamping means for clamping said plate against said first mentioned means, 75

members upstanding from said base plate adjacent the corners thereof and rigid therewith, a rigid integral rectangular openwork frame fitting on and removably carried by said last mentioned members in fixed relation to and above said base member, a bar having elongated end portions extending between the sides of said frame, said end portions fitting over and being slidable longitudinally of said sides, a shaft extending longitudinally of said bar, pinions on said shaft, racks in said sides of said frame engaged by said pinions for moving said bar, a member fitting on said bar and movable longitudinally thereon, means for moving said member, a drill bushing carried by said member and means for clamping said bar and member in fixed position.

3. A device of the class described having in combination, a base member rectangular in plan having flat sides at right angles to each other and having a top supporting flat surface adapted to receive a die plate, means on said member against which said plate may be placed to position it, movable clamping means for clamping said plate against said first mentioned means, members upstanding from said base plate adjacent the corners thereof and rigid therewith, a rigid integral rectangular openwork frame fitting on and removably carried by said last mentioned members in fixed relation to and above said base member, a bar extending across, fitting on and movable along the sides of said frame, means engaging each end of said bar and simultaneously operated for moving said bar longitudinally of said frame, a common means for operating said last mentioned means, a guide means extending longitudinally of said bar, a member fitting said guide means and movable longitudinally thereof, a rack on one side of said bar, a shaft carried by said member, a pinion secured to said shaft and meshing with said rack, means for rotating said shaft and pinion, a drill bushing carried by said member at the other side of said bar and means for locking said bar and member in fixed position.

4. A device of the class described having in combination, a base member having a top supporting flat surface adapted to receive a die plate, means on said member against which said plate may be placed to position it, movable clamping means for clamping said plate against said first mentioned means, members upstanding from said base plate adjacent the corners thereof and rigid therewith, a rigid integral rectangular openwork frame fitting on and removably carried by said last mentioned members in fixed relation to and above said base member, a bar extending across, fitting on and movable along the sides of said frame, means engaging each end of said bar and simultaneously operated for moving said bar longitudinally of said frame, a member fitting said bar and movable longitudinally thereof, means for moving said member, a drill bushing carried by said member and means for locking said bar and member in position.

5. A device of the class described having in combination, a base member having a top supporting surface adapted to receive a die plate, means on said member against which said plate may be placed to position it, movable clamping means for clamping said plate against said first mentioned means, members upstanding from said base plate adjacent the corners thereof and rigid therewith, a rigid integral rectangular openwork frame fitting on and removably carried by said last mentioned members in fixed relation to and above said base member, a bar extending across, fitting on and movable along the sides of said frame, means for moving said bar longitudinally of said frame, a member fitted on and movable longitudinally of said bar, means for moving said member, means carried by said member having an aperture therethrough for receiving a drill or punch and means for locking said bar and member in fixed position.

VITUS A. BOKER.